

**Self Compacting Concrete Incorporating
High-Volumes of Class F Fly Ash:
Preliminary Results**

by

N. Bouzoubaâ^{a*} and M. Lachemi^b

^a Research Scientist

International Centre for Sustainable Development of Cement and Concrete
(ICON)

CANMET/Natural resources Canada
405 Rochester Street, Ottawa, ON, Canada K1A 0G1

^b Assistant Professor

Department of Civil Engineering

Ryerson Polytechnic University

350 Victoria Street, Toronto, ON, Canada M5B 2K3

Cement and Concrete Research, Vol. 31, No. 3, Mar. 2001, pp. 413-420.

Keywords: Compressive strength, Concrete, Fly ash, Self compacting, Slump flow.

ABSTRACT

In recent years, self-compacting concrete (SCC) has gained wide use for placement in congested reinforced concrete structures with difficult casting conditions. For such applications, the fresh concrete must possess high fluidity and good cohesiveness. The use of fine materials such as fly ash can ensure the required concrete properties. The initial results of an experimental program aimed at producing and evaluating SCC made with high-volumes of fly ash are presented and discussed. Nine SCC mixtures and one control concrete were investigated in this study. The content of the cementitious materials was maintained constant (400 kg/m^3), while the water/ cementitious material ratios ranged from 0.35 to 0.45. The self-compacting mixtures had a cement replacement of 40, 50, and 60% by Class F fly ash. Tests were carried out on all mixtures to obtain the properties of fresh concrete in terms of viscosity and stability. The mechanical properties of hardened concretes such as compressive strength and drying shrinkage were also determined. The self-compacting concretes developed a 28-day compressive strengths ranging from 26 to 48 MPa. The results show that an economical self-compacting concrete could be successfully developed by incorporating high-volumes of Class F fly ash.

1. Introduction

Self-compacting concrete (SCC) is considered as a concrete which can be placed and compacted under its self-weight with little or no vibration effort, and which is at the same time, cohesive enough to be handled without segregation or bleeding. It is used to facilitate and ensure proper filling and good structural performance of restricted areas and heavily reinforced structural members. SCC was developed in Japan (1) in the late 1980's to be mainly used for highly congested reinforced structures in seismic regions. Recently, this concrete has gained wide use in many countries for different applications and structural configurations. SCC can also provide a better working environment by eliminating the vibration noise. There are many advantages of using SCC, especially when the material cost is minimized.

These include:

- Reducing the construction time and labor cost;
- Eliminating the need for vibration;
- Reducing the noise pollution;
- Improving the filling capacity of highly congested structural members;
- Facilitating constructibility and ensuring good structural performance.

Such concrete requires a high slump that can easily be achieved by superplasticizer addition to a concrete mixture. However, for such concrete to remain cohesive during handling operations, special attention has to be paid to mix proportioning. To avoid segregation on superplasticizer addition, a simple approach consists of increasing the sand content at the cost of the coarse aggregate content by 4 to 5 % (2,3). But the reduction in aggregate content results in using a high volume of

cement which, in turn, leads to a higher temperature rise and an increased cost. An alternative approach consists of incorporating a viscosity-modifying admixture to enhance stability (4).

Chemical admixtures are, however, expensive, and their use may increase the materials cost. Saving in labor cost might offset the increased cost, but the use of mineral admixtures such as fly ash, blast furnace slag, or limestone filler could increase the slump of the concrete mixture without increasing its cost.

Previous investigations show that the use of fly ash and blast furnace slag in self-compacting concrete reduces the dosage of superplasticizer needed to obtain similar slump flow as for concrete made with Portland cement only (5). Also, the use of fly ash improves rheological properties and reduces cracking of concrete due to the heat of hydration of the cement (6). Kim et al. (7) studied the properties of super flowing concrete containing fly ash and reported that the replacement of cement by 30% (40% for only one mixture) fly ash resulted in excellent workability and flowability. Other researchers (8) evaluated the influence of supplementary cementitious materials on workability and concluded that the replacement of cement by 30% of fly ash can significantly improve rheological properties. But to the best knowledge of the authors, the percentage replacement of cement by fly ash, in the various published studies, did not exceed 30% (except the one 40% mixture by Kim et al.) by weight of the total cementitious materials.

In the 1980's CANMET designed the so-called High-volume fly ash (HVFA) concrete. In this concrete 55-60% of the portland cement is replaced by Class F fly ash and this concrete demonstrated excellent mechanical and durability properties (9-12). In order to extend the general concept of HVFA concrete and its applications to a wider range of infrastructure construction, this paper outlines the preliminary results of a research project aimed at producing and evaluating self-compacting concretes incorporating high volumes of fly ash.

The present project investigates the making of self-compacting concrete more affordable for the construction market by replacing high volumes of portland cement by fly ash. There are, however, some differences between the HVFA self compacting concrete and the HVFA concrete designed by CANMET. A typical mixture proportion for the CANMET HVFA concrete will have a water to cementitious materials ratio of 0.32, and cement and fly ash contents of 155 and 215 kg/m³ respectively. The HVFA self compacting concrete will have higher water-to-cementitious materials ratio, ranging from 0.35 to 0.45, a slightly higher total mass of cementitious materials of 400 kg/m³ in which 40 to 60% of cement replaced by fly ash, and a mass proportion of sand and coarse aggregate of 50:50. Such concrete is flowable, cohesive and develops a 28-day compressive strength of approximately 35 MPa. The results are compared to those obtained with a conventional control concrete.

2. Materials

2.1 Cement

ASTM Type I, normal Portland cement was used. Its physical properties and chemical compositions are presented in Table 1.

2.2 Fly ash

An ASTM Class F fly ash from Alberta, Canada was used. Its physical properties and chemical compositions are presented in Table 1 as well.

The fly ash meets the general requirements of ASTM Class F ash, has relatively high CaO content of 13.4% and alkali content (Na₂O equivalent) of 4.0%. The Blaine fineness of the ash is 3060 cm²/g and the specific gravity is 2.08.

2.3 Admixtures

A sulphonated, naphthalene-formaldehyde superplasticizer, and a synthetic resin type air-entraining admixture (AEA) were used in all the concrete mixtures.

2.4 Aggregates

A crushed limestone with a maximum nominal size of 19 mm was used as the coarse aggregate, and a local natural sand was used as the fine aggregate in the concrete mixtures. The coarse aggregate was separated into different size fractions

and recombined to a specific grading shown in Table 2. The grading of the fine aggregate is presented in Table 2 as well. The coarse and fine aggregates each had a specific gravity of 2.70, and water absorptions of 0.5 and 0.8%, respectively.

3. Mixture Proportions

The proportions of the concrete mixtures are summarized in Table 3. For all the mixtures, the coarse and fine aggregates were weighed in a room dry condition. The coarse aggregate was then immersed in water for 24 hours. The excess water was decanted, and the water retained by the aggregates was determined by the weight difference. A predetermined amount of water was added to the fine aggregate that was then allowed to stand for 24 hours.

Ten concrete mixtures were tested in this program. These include one control concrete with ASTM Type I cement and nine fly ash concretes with 40, 50, and 60% cement replacement by fly ash, each having water-to-cementitious materials ratios of 0.35, 0.40, and 0.45.

The control concrete is an air-entrained concrete with a cement content of 336 kg/m³ of concrete and a water-to-cement ratio of 0.50. It has a 28-day compressive strength of 35 MPa.

For self compacting concretes, the content of the cementitious materials was maintained at 400 kg/m³ of concrete. The sand content was increased at the cost of the coarse aggregate content, thus the proportion of the aggregate used for the self compacting concretes was 50% sand, and 50% coarse aggregate by the total weight of the aggregate. The volume ratio of coarse aggregate to concrete was 0.32. All the self-compacting concretes were designed to develop a 28-day compressive strength of 35 MPa, similar to that of the control concrete.

4. Preparation and Casting of Test Specimens

All the concrete mixtures were mixed for five minutes in a laboratory counter-current mixer. From each concrete mixture, four 76×102×390-mm prisms and nine 102×203-mm cylinders were cast. The cylinders were used for the determination of compressive strength, and the prisms were cast for determining the drying shrinkage. The flow time for each concrete mixture was determined using the V-funnel test shown in Fig.1 (13). For some concrete mixtures, one container of approximately 7 L capacity was filled with the fresh concrete for determining the bleeding, one 152×152×152-mm mold was filled with mortar obtained by sieving the fresh concrete for determining the setting times of concrete, and one 152×305-mm cylinder was cast for determining the autogenous temperature rise of the concrete. The resistance to segregation of self-compacting concrete was evaluated with the test proposed by Fujiwara et al. (14).

The specimens for the control concrete were cast in two layers and were compacted on a vibrating table, while those for the self compacting concretes were cast in one layer without vibration. After casting, all the molded specimens were covered with plastic sheets and water-saturated burlap, and left in the casting room for 24 hours. They were then demolded and the cylinders were transferred to the moist-curing room at $23 \pm 2^\circ\text{C}$ and 100 % relative humidity until required for testing; the prisms for drying shrinkage were stored in lime-saturated water for 7 days prior to be transferred to a conditioned chamber at $20 \pm 2^\circ\text{C}$ and 50 % relative humidity.

5. Testing of the Specimens

5.1 Properties of fresh concrete

The slump, air content, bleeding and setting time of fresh concrete were determined following ASTM standards. The adiabatic temperature rise of the concrete was measured using a 152×305-mm cylinder of fresh concrete that had been placed in an autogenous curing chamber. The temperature of the concrete was recorded at 2-hour intervals for 4 days.

The viscosity of SCC mixtures was evaluated through the slump flow test. The slump flow represents the mean diameter of the mass of concrete after release of a standard slump cone; the diameter is measured in two perpendicular directions. According to Nagataki et al. (15), a slump flow ranging from 500 to 700 mm is

considered as the slump required for a concrete to be self-compacted. More than 700 mm, the concrete might segregate, and at less than 500 mm, the concrete is considered to have insufficient flow to pass through highly congested reinforcement.

The stability of SCC mixtures was evaluated through the V-shaped funnel test (13). The flow time was determined using a simple procedure: the funnel is completely filled with fresh concrete, and the flow time is that between opening the orifice and the complete emptying of the funnel. According to Khayat and Manai (16), a funnel test flow time less than 6 seconds is recommended for a concrete to qualify for a self-compacting concrete.

The segregation test developed by Fujiwara et al. (14) consists of gently pouring a 2-L container of fresh concrete over a 5-mm mesh, and measuring the mass of the mortar passing through the screen after 5 minutes. The segregation index, SI, is taken as the ratio of the mortar passing through the screen to that contained in the 2-L concrete sample. A stable concrete should exhibit an SI value lower than 5% (14). However, due to the simplicity of the above test, the results are not reproducible, and are very sensitive to the way the concrete is poured. Thus, the limit of 5% is considered too severe, and a limit of 10% appears more realistic (17, 18).

5.2 Mechanical properties

For each mixture, the compressive strength was determined on three cylinders at 1, 7, and 28 days. The drying shrinkage of the two prisms was measured at 7, 14, 28, 56, 112, and 224 days after an initial curing of 1 day in the mold and 6 days in lime-saturated water; the other two prisms were stored in the lime-saturated water 1 day after casting and their length changes were measured for control purposes. The two tests were carried out following the relevant ASTM standards.

6. Results and Discussion

6.1 Properties of fresh concrete

The unit weight, slump, and air content of the fresh concretes are given in Table 4, and the results on the bleeding, setting times, maximum autogenous temperature rise, and segregation index of the different concretes are given in Table 5. The autogenous temperature rise of the concrete for up to 4 days is shown in Fig. 2.

6.1.1 Slump, slump flow, flow time, and air content

The slump of the control concrete was about 110 mm, and those of fly ash self-compacting concretes were approximately 240 mm. The slump flow of the self-compacting concretes was in the range of 450 to 650 mm, and the funnel test flow times were in the range of 3 to 7 seconds. All self-compacting mixtures (except Mixture #8) presented a slump flow between 500 and 700 mm which is an

indication of a good deformability. The different SCCs performed well in term of stability since all mixtures (except one) exhibited a flow time below 6 seconds.

The slump flow seems to be more related to the dosage of superplasticizer than to the percentage of the fly ash or to the water-to-cementitious materials ratio used. However, the dosage of the superplasticizer of the self-compacting concrete that ranged from 0 to 3.8 L/ m³ of concrete seems to increase with a decrease in both the water-to-cementitious materials ratio and the percentage of fly ash used. For all SCC mixtures, the flow time increased with a decrease in the water content.

The dosage of the air-entraining admixture (AEA) required for obtaining an air content of 5 to 7 % was about 67 mL/m³ for the control concrete, and ranged from 338 to 483 mL/m³ for the self-compacting concretes.

6.1.2 Bleeding, setting time, autogenous temperature rise, and segregation index

The total amount of the bleeding water of the control concrete was of 0.065 mL/cm², and that of the self-compacting concrete ranged from 0.025 to 0.129 mL/cm². The bleeding water increased with an increase in the water-to-cementitious materials ratio. In fact, the highest bleeding water recorded was for the self-compacting concretes made with W/(C+FA) of 0.45; this might, consequently reduce the strength of the top surface of the concrete. The increase of the percentage of the fly ash from 40 to 60% of the total weight of the cementitious

materials did not significantly influence the bleeding water of the self-compacting concrete.

The initial and final setting times of concrete ranged from 4:50 to 7:45 h:min., and from 6:30 to 10:15 h:min., respectively (Table 5). The times of setting of the self-compacting concretes were 3 to 4 hours longer than those determined on the control concrete. This was expected, considering the high dosage of superplasticizer and the low cement content in the self-compacting concrete mixtures. This is in line with a previous investigation (19).

Data in Table 5 show that the maximum temperature rise of the control concrete was 23.4°C, and the maximum temperature rise for the self-compacting concretes was considerably lower, and ranged from 13.6 to 18.6°C. This demonstrates the potential of high-volume fly ash self-compacting concrete system for reducing the temperature rise in large concrete members due to its low cement content and the slow reaction process of fly ashes.

Figure 2 shows heat evolutions of mixtures 1, 2, 5, and 8. It also illustrates the higher temperature in the control concrete, and the lower temperature in self-compacting concrete incorporating high volumes of fly ash.

Table 5 shows that the segregation index of the SCC mixtures investigated (Mixtures 2, 3, 4, 5, and 8) ranged from 1.9 to 14%. The segregation index of the concrete mixtures with similar water-to-cementitious materials ratio (0.45) decreased with an increase of the percentage of the fly ash used. While, for the concrete mixtures with similar fly ash content (40%), the segregation index increased with an increase in the dosage of superplasticizer that accompanied the decrease of the water-to-cementitious ratio. If a segregation index of maximum 10% is considered as the limit for a concrete mixture to exhibit good resistance to segregation (18), then the self-compacting concrete mixtures with water-to-cementitious materials ratio of 0.45 shall be considered as resistant to segregation.

6.2 Mechanical properties

6.2.1 Compressive strength

The compressive strength of the different concretes is shown in Table 6. The control concrete developed compressive strengths of 16.7, 27.3 and 34.6 MPa, at 1, 7, and 28 days, respectively. The self compacting concretes developed compressive strengths ranging from 4.9 to 16.6, 14.7 to 31.3 and from 26.2 to 48.3 MPa at 1, 7, and 28 days.

The compressive strength increased with a decrease in the percentage of the fly ash and the water-to-cementitious materials ratio. Apart from mixtures 8 and 9 made

with 60% of fly ash and a water-to-cementitious materials ratio of 0.40 and 0.45, all the remaining concrete mixtures achieved the targeted 28-day compressive strength of approximately 35 MPa.

Table 7 presents the pricing cost of the concrete mixtures investigated based on the cost of the materials only. The cost was based on prices used in the western Canada market, all figures are in Canadian Dollars. The prices used were \$140 a tonne for cement, \$80 a tonne for fly ash, and \$4 a litre for superplasticizer. The cost did not include the price related to the vibration of the concrete.

The table shows that the cheapest concrete mixture that achieved the targeted 28-day compressive strength of approximately 35 MPa is the control concrete followed by the self compacting concrete made with 50% of fly ash and with a water-to-cementitious materials ratio of 0.45. The costs of the above two mixtures are \$47.0 and \$48.2 per 1 m³ of concrete, respectively. This shows that a concrete with a 28-days compressive strength of 35 MPa can be replaced by a self-compacting concrete with no significant extra cost. Such self-compacting concrete would be flowable with a slump flow and flow time of approximately 500 mm and 3 seconds, respectively; the concrete is likely to be resistant to segregation and to thermal cracking caused by the heat of hydration of the cement. However, such self-compacting concrete might exhibit high bleeding water and long setting times.

6.2.2 Drying shrinkage

The drying shrinkage strains for the concretes investigated were low, and did not exceed 600×10^{-6} at 224 days (Table 8). No difference was noticed between the drying shrinkage of the control concrete and that of the self compacting concrete. In fact, the drying shrinkage of the control concrete was of 541×10^{-6} at 224 days, and that of the self compacting concrete ranged from 504 to 595×10^{-6} at 224 days.

7. Conclusion

The present investigation has shown that it is possible to design a self-compacting concrete incorporating high-volumes of Class F fly ash. The high-volume fly ash self compacting concretes (except one) have a slump flow in the range of 500 to 700 mm, a flow time ranging from 3 to 7 seconds, a segregation index ranging from 1.9 to 14%, and bleed water ranging from 0.025 to 0.129 mL/cm². The temperature rise of the self compacting concrete was 5 to 10 °C lower than that of the control concrete, and the setting times of the self-compacting concrete were 3 to 4 hours longer than those of the control concrete. The self-compacting concrete developed compressive strengths ranging from 15 to 31 MPa, and from 26 to 48 MPa, at 7 and 28 days, respectively.

In terms of mix design cost, the economical self compacting concrete that achieved a 28-day compressive strength of approximately 35 MPa was that made with 50%

replacement of cement by fly ash, and with a water-to-cementitious materials ratio of 0.45. This self compacting concrete can replace the control concrete with similar 28-day compressive strength (35 MPa) with no significant extra cost. However, it should be noted that only one fly ash has been used in the present study, and further research is needed in the area.

REFERENCES

1. K. Ozawa, K. Maekawa, M. Kunishima, and H. Okamura, "Performance of Concrete Based on the Durability Design of Concrete Structures", Proc. Of the Second East Asia-Pacific Conference on Structural Engineering and Construction, 1989.
2. P. K. Mehta, "Concrete Structure, Properties and Materials", Prentice-Hall, Inc., 1986, p. 367-378.
3. A. M. Neville, "Properties of Concrete", Fourth Edition, Longman Group Limited., 1995, p. 757-758.
4. K. H. Khayat and Z. Guizani, "Use of Viscosity-Modifying Admixture to Enhance Stability of Fluid Concrete", ACI Materials Journal, 1997, Vol. 94, No. 4, pp. 332-341.

5. A. Yahia, M. Tanimura, A. Shimabukuro and Y. Shimoyama, “Effect of Rheological Parameters on Self Compactability of Concrete Containing Various Mineral Admixtures”, Proceedings of the first RILEM International Symposium on Self-Compacting Concrete, Stockholm, September 1999, pp. 523-535 (ed.: A. Skarendahl and O. Petersson).

6. M. Kurita and T. Nomura, “Highly-Flowable Steel Fiber-Reinforced Concrete Containing Fly Ash”, ACI Special Publication SP-178, June 1998, pp. 159-175 (ed.: V. M. Malhotra).

7. J.K. Kim, S.H. Han, Y.D. Park, J.H. Noh, C.L. Park, Y.H. Kwon, and S.G. Lee, “Experimental Research on the Material Properties of Super Flowing Concrete”, Production Methods and Workability of Concrete, E & FN Spon, 1996, pp. 271-284 (ed.: P.J.M. Bartos, D.L. Marris, and D.J. Cleland).

8. N. Miura, N. Takeda, R. Chikamatsu, and S. Sogo, “Application of Super Workable Concrete to Reinforced Concrete Structures with Difficult Construction Conditions”, Proceedings, ACI SP 140, pp. 163-186.

9. V. Sivasundaram, "Thermal Crack Control of Mass Concrete", MSL Division Report MSL 86-93 (IR) Energy Mines and Resources Canada, Ottawa, 1986, 32 pp.
10. V.M. Malhotra, "Superplasticizer Fly Ash Concrete for Structural Applications", ACI Concrete International, Vol. 8, No. 12, December 1986, pp. 28-31.
11. V.M. Malhotra, "High-Performance High-Volume Fly Ash Concrete", Proceedings of International Conference on High-Performance High-Strength Concrete, BV. Rangan and A.K. Patnaik, eds., 1998, pp. 97-122.
12. A Bilodeau and V.M. Malhotra, "High-Volume Fly Ash System: Concrete Solution for Sustainable Development", ACI Materials Journal, 2000, Vol. 97, No. 1, pp. 41- 48.
13. K. Ozawa, N. Sakata, and H. Okamura, "Evaluation of Self-Compatibility of Fresh Concrete Using the Funnel Test", Proceedings, Japan Society of Civil Engineering, No. 25, June 1995, pp. 59-75.

14. H. Fujiwara, "Fundamental Study on the Self-Compacting Property of High-Fluidity Concrete", Proceeding of the Japan Concrete Institute, Vol. 14, No. 1, pp. 27-32, June 1992, pp. 27-32.
15. S. Nagataki and H. Fujiwara, "Self-Compacting Property of Highly-Flowable Concrete", ACI Special Publication SP-154, June 1995, pp. 301-314 (ed.: V. M. Malhotra)
16. K. H. Khayat and K. Manai, "Les Bétons Autonivlants: Propriétés, caractérisation et applications", Colloque sur les bétons autonivlants, Université de Sherbrooke, Canada, Nov. 1996, 28 p.
17. K. H. Khayat, Personal communication, August 2000.
18. K. H. Khayat, A. Ghezal, and M. S. Hadriche, "Development of Factorial Design Models for Proportioning Self-Consolidating Concrete", Nagataki Symposium on Vision of Concrete: 21st Century, June 1998, pp. 173-197 (ed.: V. M. Malhotra).
19. T. Fukute, A. Moriwake, K. Sano, and K. Hamasaki, "Development of Superworkable Concrete for Multi-Functional Port Structures", ACI Special Publication SP-154, June 1995, pp. 335-356. (ed.: V. M. Malhotra)

Table 1 - Physical properties and chemical analyses of the materials used

	ASTM cement Type I	ASTM Class F fly ash	ASTM C 618 Class F
<u>Physical tests</u>			
Specific gravity	3.17	2.08	-
Fineness			
-passing 45 μ m, %	94	83.6	66.0 min.
-specific surface, Blaine, cm ² /g	4070	3060	-
Compressive strength of 51 mm cubes, MPa			
-7-day	26.0	-	-
-28-day	31.9	-	-
Water requirement, %	-	99.2	105 max.
Pozzolanic Activity Index, %			
-7-day	-	94.5	75 min.
-28-day	-	106.9	75 min.
Time of setting, Vicat test, min			
-initial setting	220	-	-
-final setting	325	-	-
Air content of mortar, volume %	5.5	-	-
<u>Chemical analyses, %</u>			
Silicon dioxide (SiO ₂)	20.3	52.4	SiO ₂ +Al ₂ O ₃ + Fe ₂ O ₃ > 70%
Aluminium oxide (Al ₂ O ₃)	4.2	23.4	
Ferric oxide (Fe ₂ O ₃)	3.0	4.7	-
Calcium oxide (CaO)	62.0	13.4	-
Magnesium oxide (MgO)	2.8	1.3	-
Sodium oxide (Na ₂ O)	0.2	3.6	-
Potassium oxide (K ₂ O)	0.9	0.6	-
Equivalent alkali (Na ₂ O+0.658K ₂ O)	0.8	4.0	-
Phosphorous oxide (P ₂ O ₅)	0.2	0.2	-
Titanium oxide (TiO ₂)	0.2	0.8	5.0 max.
Sulphur trioxide (SO ₃)	3.5	0.2	6.0 max.
Loss on ignition	2.0	0.3	
<u>Bogue potential compound composition</u>			
Tricalcium silicate C ₃ S	60	-	-
Dicalcium silicate C ₂ S	13	-	-
Tricalcium aluminate C ₃ A	6	-	-
Tetracalcium aluminoferrite C ₄ AF	9	-	-

Table 2 - Grading of the coarse and fine aggregate

Coarse aggregate		Fine aggregate	
Sieve size, mm	Passing, %	Sieve size, mm	Passing, %
19.0	100	4.75	97.1
12.7	67	2.36	87.6
9.5	34	1.18	76.7
4.75	0	0.60	52.4
		0.30	16.6
		0.15	4.0

Table 3 - Proportions of the concrete mixtures

Mix. no	$\frac{W}{(C+FA)}$	Water	Cement kg/m ³	Fly ash		Fine aggregate, kg/m ³	Coarse aggregate, kg/m ³	AEA, mL/m ³	SP, L/m ³
				%	kg/m ³				
1	0.5	167	336	-	-	739	1105	67	0
2	0.45	186	247	40	165	845	846	338	1.2
3	0.4	159	238		159	844	844	355	2.9
4	0.35	136	232		155	846	847	345	3.8
5	0.45	188	207	50	207	845	843	356	0.4
6	0.4	161	200		200	842	843	372	1.7
7	0.35	138	197		197	856	856	338	2.8
8	0.45	190	169	60	254	853	853	483	0
9	0.4	164	163		245	851	851	394	2
10	0.35	141	161		241	866	864	345	3

Table 4 - Properties of the fresh concrete

Mixture no.	W/(C+FA)	% of fly ash	Unit weight, kg/m ³	Slump, mm	Slump flow, mm	Funnel test flow time, sec	Air content, %
1	0.5	-	2350	110	-	-	5.6
2	0.45	40	2291	240	625	3	4
3	0.4		2250	240	625	4	7.7
4	0.35		2220	240	650	7	7.9
5	0.45	50	2290	230	520	3	4.3
6	0.4		2250	240	570	5	6
7	0.35		2250	240	540	6	7.7
8	0.45	60	2320	230	450	3	3
9	0.4		2280	240	600	3	6.2
10	0.35		2280	240	650	4	5.8

Table 5 - Bleeding, setting time, and maximum autogenous temperature rise of concrete

Mix. no.	W/(C+FA)	% of fly ash	Total bleeding water, mL/cm ²	Setting time, h:min		Maximum autogenous temperature rise, °C	Segregation Index, % (6)
				Initial	Final		
1	0.5	-	0.065	4:48	6:28	23.4	-
2	0.45	40	0.117	6:57	9:50	18.6	4.3
3	0.4		0.082	7:40	10:19	-	13
4	0.35		0.025	6:43	9:07	-	14
5	0.45	50	0.129	6:57	10:04	17	5.2
8	0.45	60	0.127	7:26	10:04	13.6	1.9

Table 6 - Compressive strength of concrete

Mixture no.	W/(C+FA)	% of fly ash	Density of hardened concrete (1-d) kg/m ³	Compressive strength, MPa		
				1 d	7 d	28 d
1	0.5	-	2358	16.7	27.3	34.6
2	0.45	40	2318	8.7	21.2	34.6
3	0.4		2256	10.7	25.8	37.8
4	0.35		2242	16.6	31.3	48.3
5	0.45	50	2310	6.1	17.4	33.2
6	0.4		2262	7	19.3	34.9
7	0.35		2264	7.8	22.9	38.9
8	0.45	60	2330	5.2	15.6	30.2
9	0.4		2248	4.9	14.7	26.2
10	0.35		2292	7.3	20.6	35.8

Table7 Mix pricing of the self compacting concretes compared to that of the control concrete

Mix no.	Mix design			Mix pricing				Price per 1 MPa at 1, 7, and 28 days		
	Cement (kg)	Fly ash (kg)	SP (L)	Cement at \$140/t	Fly ash at \$80/t	SP at \$4/L	Total cost (\$)	1 day	7 day	28 day
1	336	-	-	47	0	0	47	2.9	1.7	-
2	247	165	1.2	34.6	13.2	4.8	52.6	6	2.5	1.5
3	238	159	2.9	33.3	12.7	11.6	57.6	5.4	2.2	1.5
4	232	155	3.8	32.5	12.4	15.2	60.1	6.7	2.9	2.1
5	207	207	0.4	30	16.6	1.6	48.2	7.9	2.8	1.4
6	200	200	1.7	28	16	6.8	50.8	7.3	2.6	1.5
7	197	197	2.8	27.6	15.8	11.2	54.6	7	2.4	1.4
8	169	254	0	23.7	20.3	0	44	8.3	2.8	-
9	163	245	2	22.8	19.6	8	50.4	10.3	3.4	1.9
10	161	241	3	22.5	19.3	12	53.8	7.4	2.6	1.5

Table 8 - Drying shrinkage test results after 7 days of curing in lime-saturated water

Mixture no.	W/(C+FA)	% of fly ash	Drying shrinkage strain, x 10 ⁻⁶					
			7 d	14 d	28 d	56 d	112 d	224 d
1	0.5	-	178	269	370	421	493	541
2	0.45	40	200	330	435	515	566	562
3	0.4		218	352	461	519	591	591
4	0.35		221	334	457	515	533	533
5	0.45		50	174	341	443	519	555
6	0.4	221		337	432	472	515	504
7	0.35	232		348	432	464	504	512
8	0.45	60	-	-	-	-	-	-
9	0.4		207	312	366	461	555	595
10	0.35		232	323	425	486	508	526

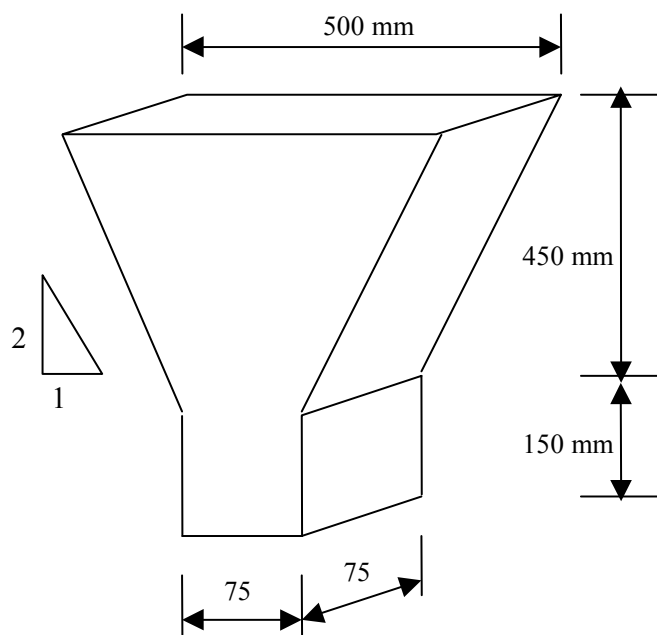
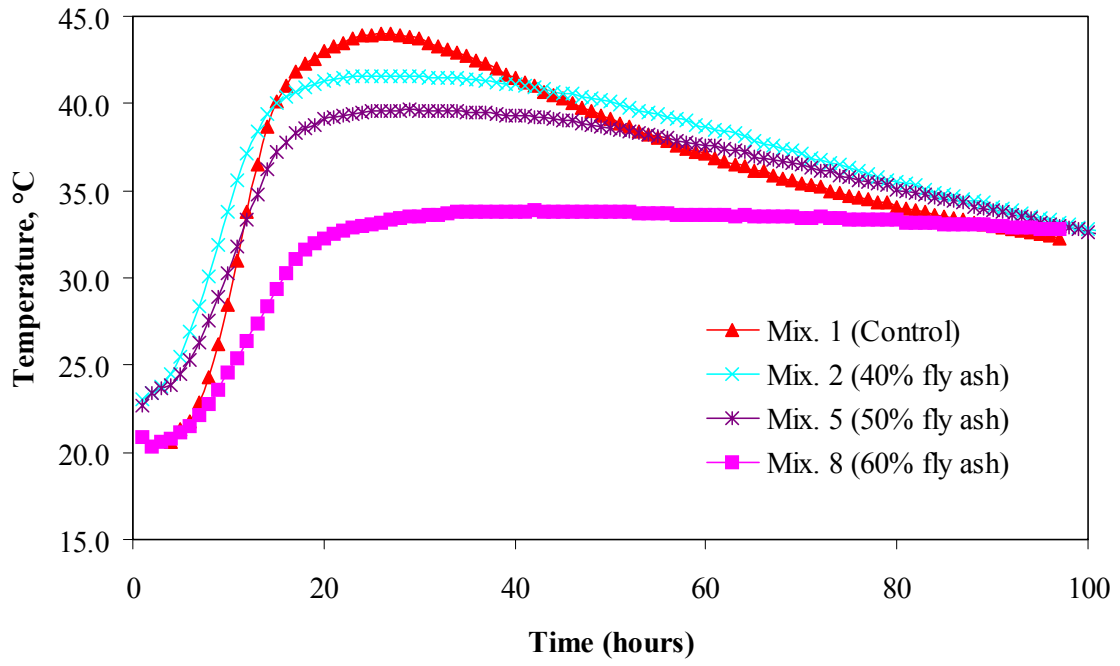

Fig. 1 – V-funnel test



Fig

. 2 - Autogenous temperature rise in 152 x 305 - mm concrete cylinder